

Gamme de sacs développée par MOBILIS pour les utilisateurs du vélo au quotidien.

Grands volumes, éléments de sécurité & de visibilité et résistance à l'eau : ces sacs sont pensés pour vous accompagner dans tous vos déplacements. Universels et adaptables, ils se fixent rapidement & simplement sur tous les vélos.



### SAC À DOS / SACOCHE VÉLO - 25L

#### CAPACITÉ 25L

Ref. 070001

NOTICE D'INSTALLATION  
EN DERNIÈRE PAGE



SYSTÈME DE FIXATION  
AU PORTE-BAGAGES

MATIÈRE ÉTANCHE  
EN TARPAULIN



SANGLE  
ANTI-BASCULEMENT



COUTURES  
ÉTANCHES

GRAND  
COMPARTIMENT-25L

ÉLÉMENTS  
RÉFLÉCHISSANTS



### LES PLUS

Compartiment PC renforcé



Jusqu'à 15.6"

Poche pour bretelles

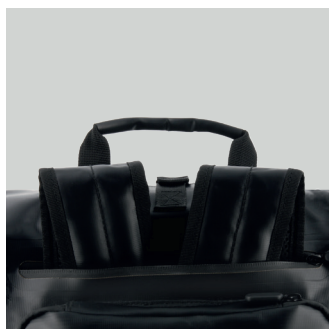

Sangle pectorale

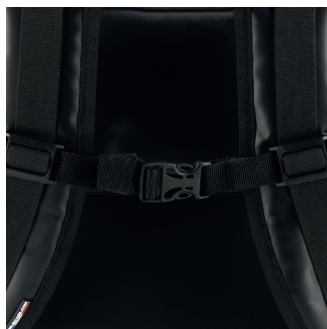

Fermeture roll-top + velcro



Poche latérale



Bandoulière amovible



### SPÉCIFICATIONS

Ref	Désignation produit	Code EAN	
070001	Bike Backpack/ Pannier 25L 14-15.6" - Black	3700992527970	
Poids	Dimensions intérieures	Dimensions extérieures	Quantité PCB
1348 g Avec pack 1350 g	450 x 340 x 180 mm	450 x 350 x 200 mm	8





1

## RANGÉZ LES BRETELLES DU SAC PUT AWAY THE BAG'S STRAPS



Déclipser  
Unclip



Ranger dans la poche dédiée  
Store in the dedicated pocket

2

## OUVREZ LA POCHE DU SYSTÈME DE FIXATION OPEN THE FASTENING SYSTEM POCKET



3

## RÉGLEZ L'ESPACEMENT ENTRE LES 2 CROCHETS DE FIXATION SELON VOTRE PORTE-BAGAGES ADJUST THE SPACING BETWEEN THE 2 FIXING HOOKS ACCORDING TO YOUR LUGGAGE RACK

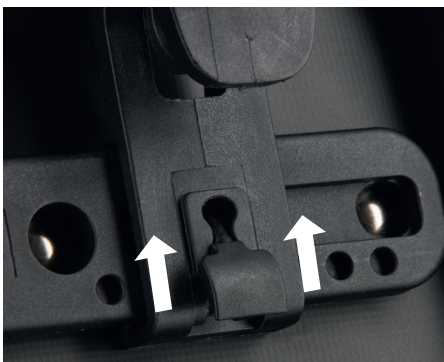

Soulever le loquet  
Lift the latch

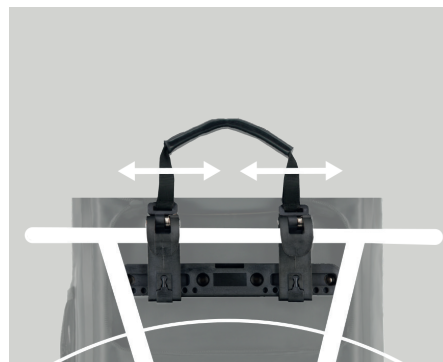

Ajuster les crochets en largeur  
Adjust the hooks in width

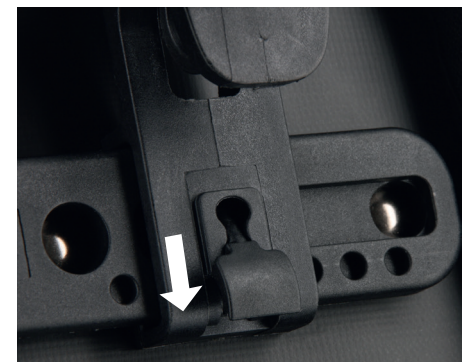

Fermer le loquet  
Close the latch

4

**CHOISISSEZ LE JOINT ADAPTÉ AU DIAMÈTRE DE VOTRE PORTE-BAGAGES**  
**CHOOSE THE RIGHT SEAL FOR THE DIAMETER OF YOUR LUGGAGE RACK**

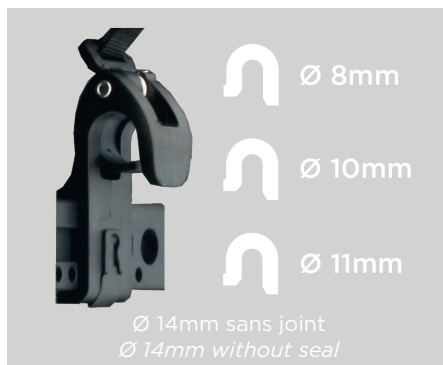

Choisir le joint adapté  
*Choosing the right seal*

Placer le joint dans le crochet  
*Place the seal in the hook*

**INSTALLATION SUR LE PORTE-BAGAGES / INSTALLATION ON THE LUGGAGE RACK**

1

**TIREZ SUR LA POIGNÉE SITUÉE AU-DESSUS DES CROCHETS POUR LES OUVRIR**  
**PULL THE HANDLE ABOVE THE HOOKS TO OPEN THEM**

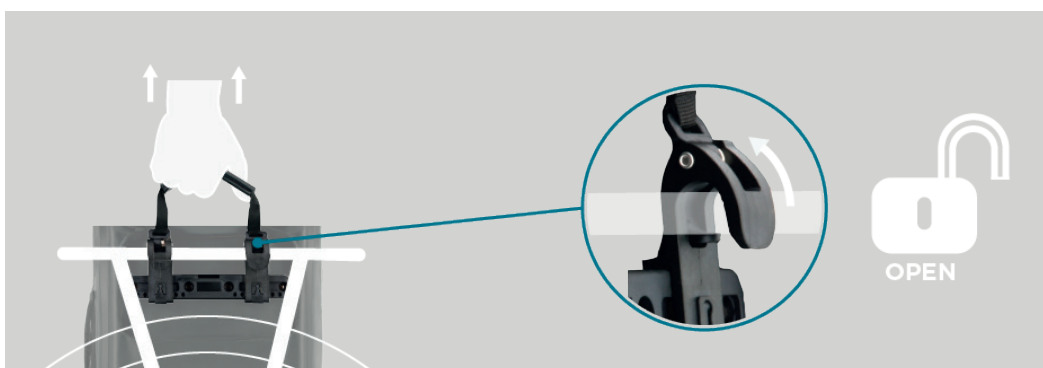

2

**RELÂCHEZ LA UNE FOIS LE SAC POSITIONNÉ SUR VOTRE PORTE-BAGAGES**  
**RELEASE IT ONCE THE BAG IS POSITIONNÉ SUR VOTRE PORTE-BAGAGES**



3

**VOUS POUVEZ ACCROCHER UNE SANGLE AU BAS DU PORTE-BAGAGES**  
**YOU CAN ATTACH A CLIP LOOP TO THE BOTTOM OF THE LUGGAGE RACK**

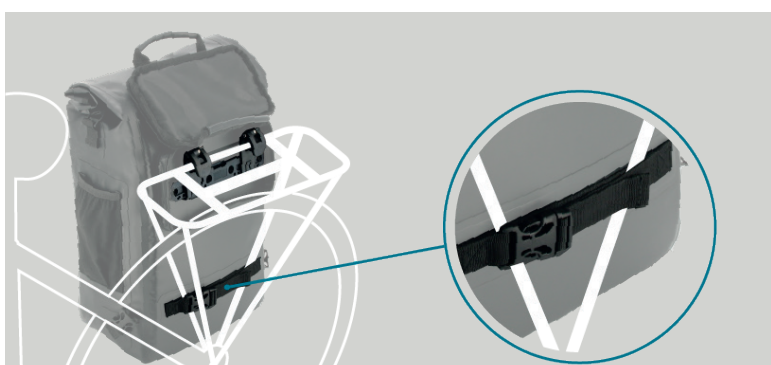

Sécurisation et anti-basculement  
*Safety and anti-tilt*