

To facilitate and secure the daily use of your smartphone or tablet, MOBILIS[®] has created the unique U.FIX range of mounts for these devices. You can now take them with you throughout your daily activities.



WINDSCREEN MOUNT FOR SMARTPHONE

Ref. 044006

SUCTION MOUNTING



MAGNETIC
DOCKING



Weight: 134 g | Dimensions: 150 x 70 x 75 mm

WINDSCREEN MOUNT FOR SMARTPHONE

PLUS-PRODUCTS

Metal plate



Windscreen mount

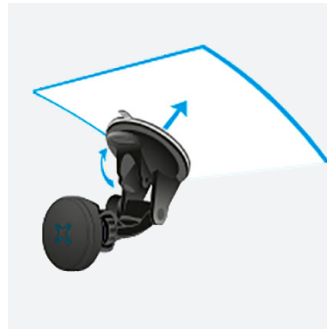

Magnetic system



- + Securely attaches to your windscreen thanks to its powerful suction mounting
- + Compatible with all smartphones : thanks to the metal plates provided (2) - attach it to the back of your smartphone or its case
- + Introducing the magnetic QuickLock mounting system: attach your smartphone in the blink of an eye
- + 360° rotation for your smartphone

SPECIFICATIONS

Ref	Product designation	EAN code	
044006	U.FIX Universal Car Nav. Kit	3700992505817	
Packed product weight	Packed product dimensions	SPCB quantity	PCB quantity
194 g	200 x 105 x 53 mm	6	24



www.mobiliscase.com



MOBILIS
CARE & CARRY